



TOMRA RollPac

Take efficiency to new heights



FLEXIBLE LINE



The backroom solution made for your handling system

The TOMRA RollPac vertical backroom solution is designed with retailers' existing roller cage infrastructure in mind. Now it's easier than ever to make room for recycling in your store's operations.



Reuse and reduce your investment

Upgrade your backroom solution for higher volume and ease of operations, while keeping your existing front-end machine and equipment. Compatible with TOMRA T8, TOMRA T9, and the new TOMRA R2, as well as various TOMRA end-of-lane configuration kits like tables and SoftDrop.



High efficiency gives you more time with your customers

Between single-person operation and a generous container capacity, the TOMRA RollPac solution helps reduce effort and increase operational efficiency, enabling more time for customers.

Save space in a smart way

TOMRA's first ever vertical compaction and storage solution handles a high volume of bottles and cans in the smallest system footprint, so you can make the most of your storage and retail sales space.



The flexible backroom solution made for an easy fit

Enjoy the benefits of an efficient backroom solution in a small space, thanks to the TOMRA RollPac's many available configurations. Reuse your existing TOMRA front-end solution and end-of-lane configuration kit.

System layout options:

TOMRA RollPac right with TOMRA T9

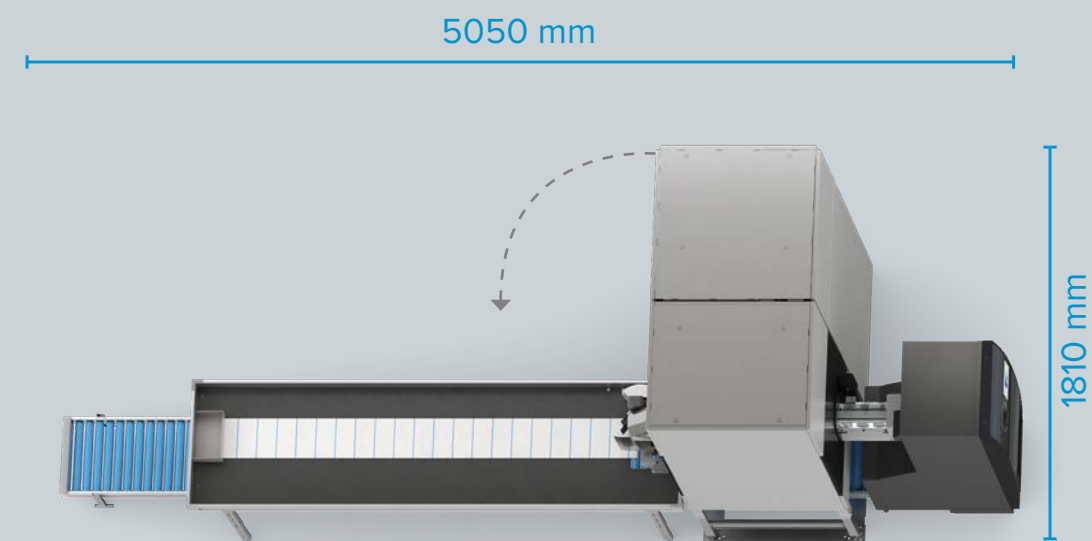

TOMRA RollPac left with TOMRA T9

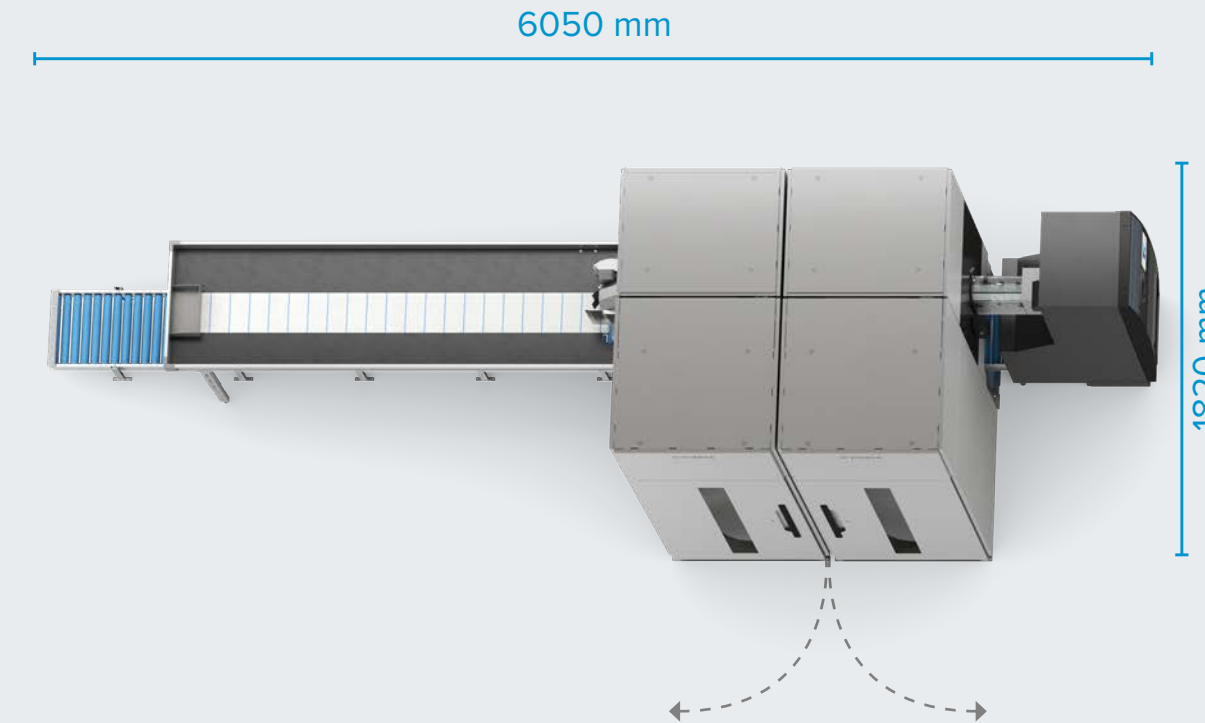

TOMRA RollPac left, angled with TOMRA T9

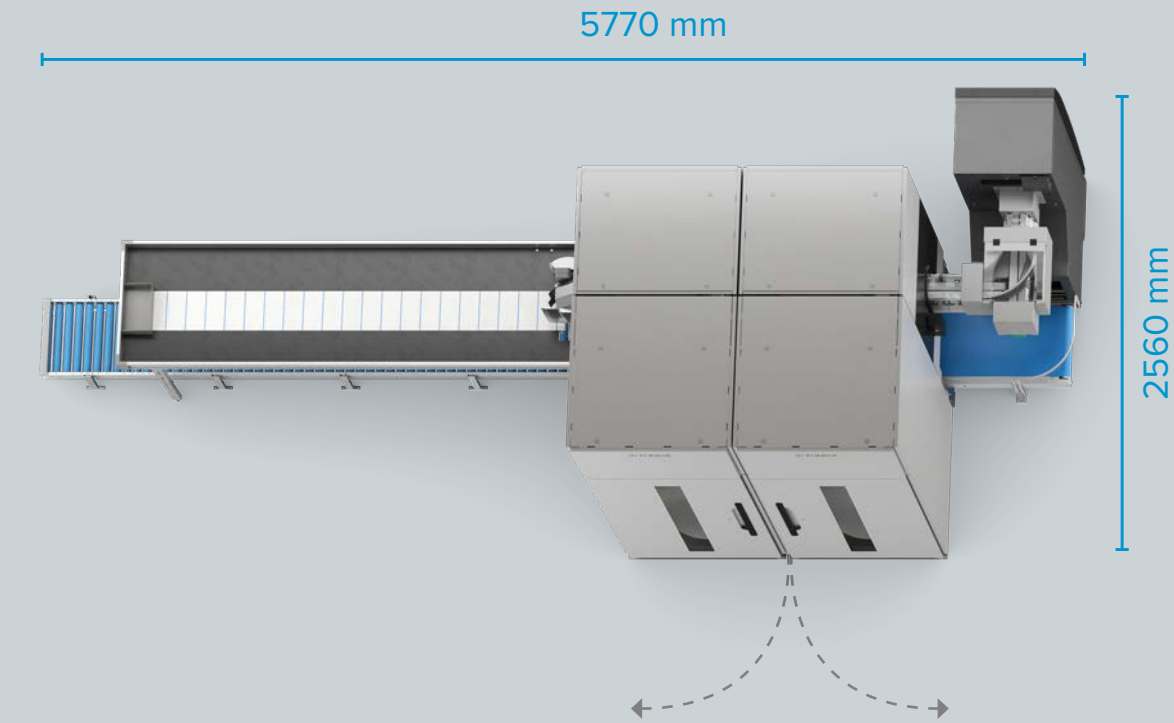

TOMRA RollPac left with TOMRA T9

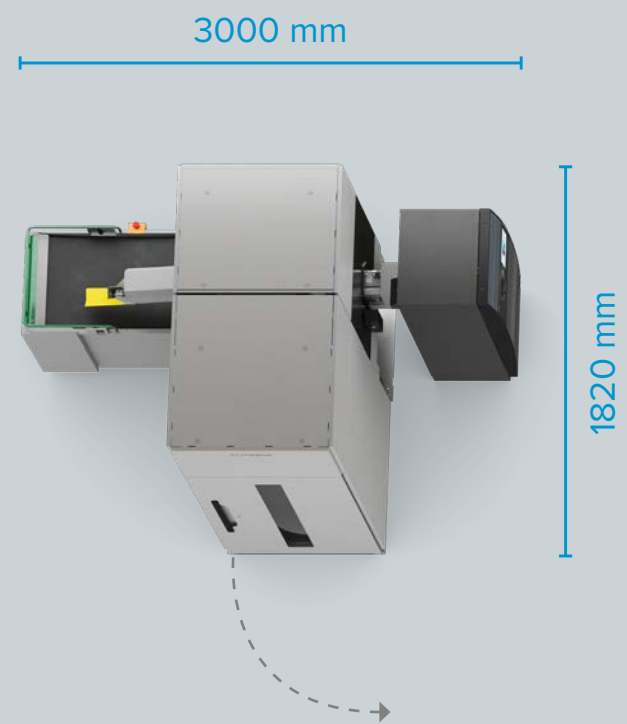

TOMRA RollPac left with turn-out and TOMRA T9

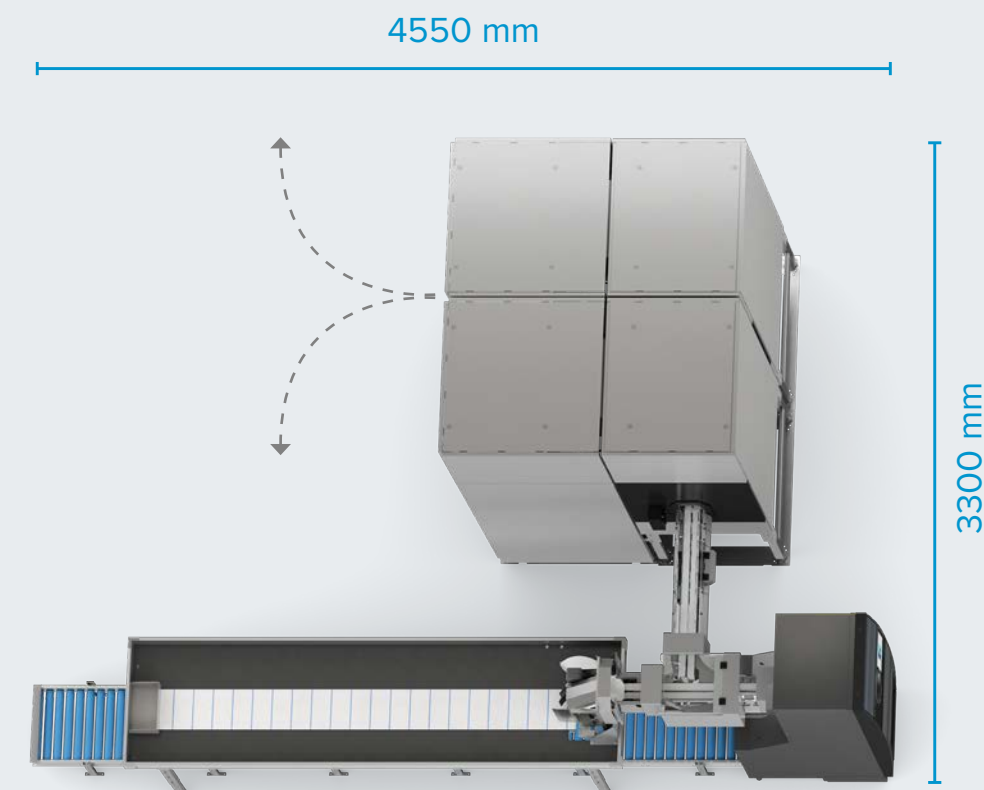

TOMRA RollPac left with spacing and TOMRA T9

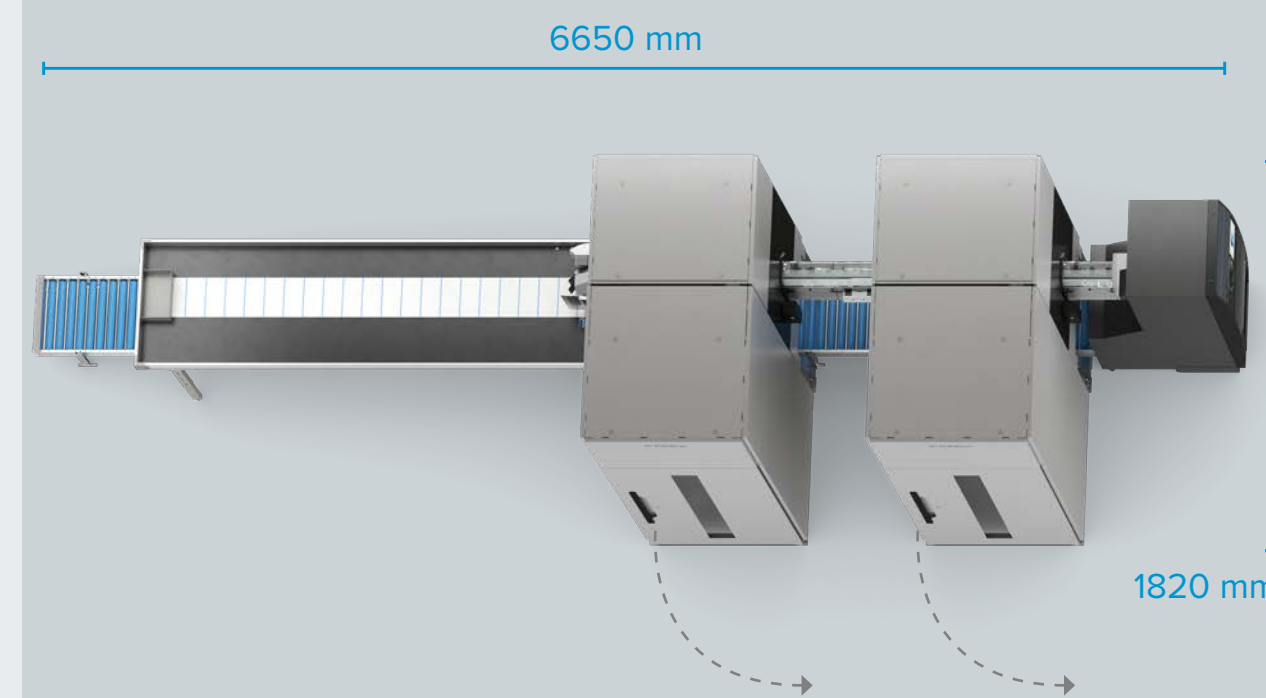

TOMRA RollPac left with TOMRA R2

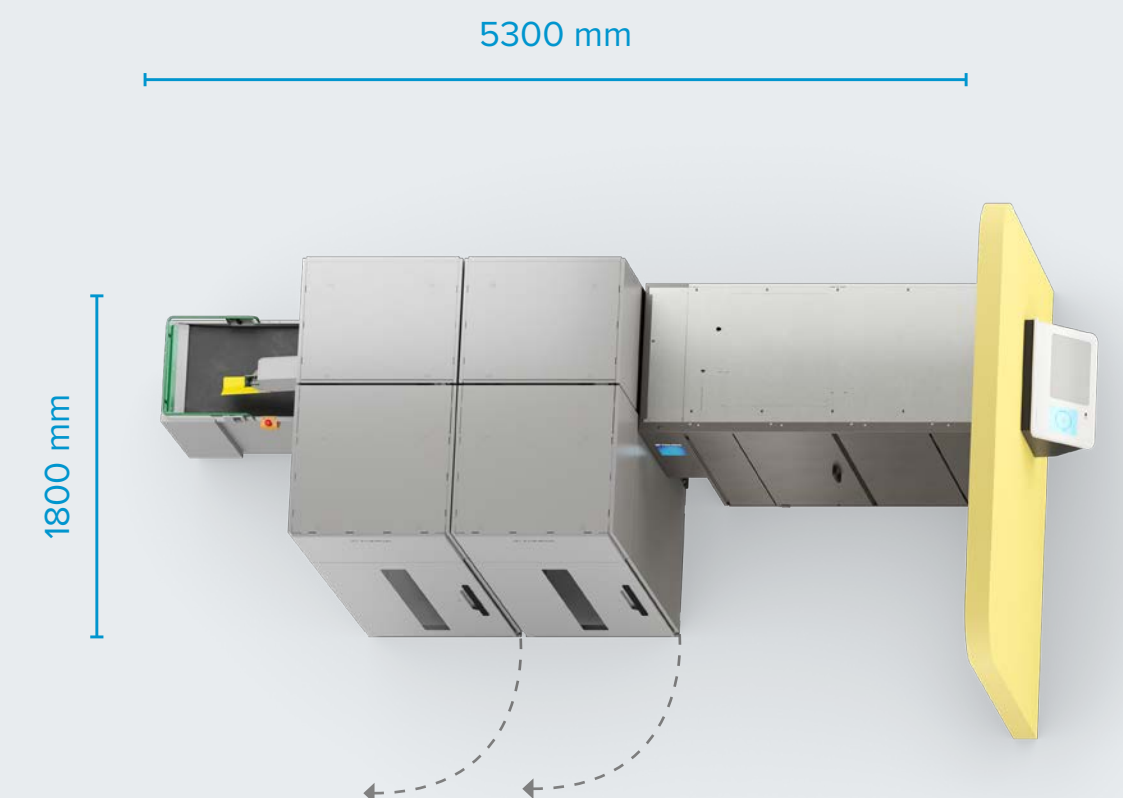

Retailers play a key role in transforming the way society handles valuable resources

Deposit return systems (DRSs) for beverage container recycling help keep valuable resources in a continuous loop of use and reuse. At TOMRA, we call this process Clean Loop Recycling.

As a retailer, you're at the heart of Clean Loop Recycling. You play a critical role at the point where consumers buy and return their containers.



Let's put recycling to work for you

Choosing to partner with TOMRA means creating a **great recycling experience for your customers**, making a **smart investment for your store**, and choosing a solution that brings **peace of mind and excellent support for your operations**.

TOMRA RollPac

Take efficiency to new heights



TOMRA RollPac / ENG/11.2024

MEASUREMENTS (PER CABINET)*

Dimensions [W x D x H]	1800 mm x 1000 mm x 2600 mm
Footprint	1.8 sqm
Weight	570 kg

STANDARD CONFIGURATION*

Machine type	Modular backroom solution
Layout/orientation	Straight, angled right/left or with turn-out (intersection)
Cabinet types	Right and left
Number of cabinets per system	1-7
Number of compactors per cabinet	1
Number of bins per cabinet	1 roller cage with max. dimensions of 760 x 820 x 1910 mm (W x D x H)
Type of compactors	PET, mix
Bin unload direction	Straight, left or right
End of lane configurations	Table with bottle raiser, end default and SoftDrop
Colors	Two-tone grey and black
User interface	Push-button
Compatible consumer-facing machines	TOMRA R2, T9 Bottle, T9 Bottle Crate, T8 Bottle and T8 Bottle Crate

STORAGE CAPACITY (PER BIN)*

Accepted containers	Non-refillable plastic bottles and cans
Storage capacity per bin	PET bottles: Up to 2200 (compacted) Cans: Up to 8000 (compacted) 50/50 mixed PET bottles/cans: 3000 (compacted using mix crusher)
Container sizes	Bottle size: Diameter 50-130 mm, height 85-380 mm Can size: Diameter 50-100 mm, height 80-200 mm

* May vary in different countries due to variations in beverage container materials, shapes and sizes, as well as variation in roller cage specifications.

ENVIRONMENTAL

Humidity	Maximum 90% relative humidity, non-condensing
Temperature	+10°C to +40°C / +50°F to 104°F (For indoor or protected installation only)
Noise	Equivalent continuous sound pressure: LAeq <71 dB

ELECTRICAL

Power consumption	Max. 1.98 kW (The power consumption of the system depends on the compactors and the system configuration.)
Mains EU	400V AC – 3-phase w/ ground, 50Hz, 16A

CONNECTIVITY

External IT interface	LAN (Ethernet TCP/IP), POS compatible
Digital tools	Fully compatible with TOMRA's portfolio of digital products and APIs



Get in the Loop at: tomra.com/reverse-vending



TOMRA CERTIFICATION
TOMRA SYSTEMS ASA has implemented and maintains a Quality and Environmental Management System which fulfils Nemko's provisions for Management System Certification and the requirements of standards NS-EN ISO 9001:2015 and NS-EN ISO 14001:2015, with the scope described by the organization on 2018-05-29. The certification covers the development and delivery of automated systems for recycling.



LEGAL COMPLIANCE
The CE mark on this product confirms compliance with the following European Directives:
2006/42/EU, Community Legislation on Machinery.
2014/30/EU, Electromagnetic Compatibility (EMC).
2011/65/EU, Restrictions of Hazardous Substance (RoHS).
2012/19/EU, Waste Electrical and Electronic Equipment (WEEE).

We reserve the right to make changes to specifications without prior notice. While every effort has been made to ensure all information contained in this document is accurate, TOMRA assumes no liability for any errors, inaccuracies or omissions that may occur. All products and offers are subject to country availability. Please consider the environment before printing.

TOMRA Collection

TOMRA Collection is part of the TOMRA Group, which is Leading the Resource Revolution by transforming how we obtain, use, and reuse our world's resources.

With approximately 85,000 installations across more than 60 markets, retailers and consumers around the world rely on our reverse vending machines to collect more than 46 billion used bottles and cans each year, which can be recycled into new containers.

Clean Loop Recycling is the easy and rewarding way to make choices that make change.

Get in the Loop at [tomra.com](https://www.tomra.com)

